

ALUFIRE[®]

fire-resistant
aluminium joinery systems

**FIRE-RESISTANT
GLAZING SOLUTIONS
CATALOGUE**

VISION LINE | CLASSIC LINE

ALUFIRE was founded in **1993** as a producer of regular aluminium joinery. In **2004**, our constructors drew up the ALUFIRE fire-resistant ODM system and the company had it certified. Thereafter, Alufire obtained Building Research Institute **approval**. Since then, the Company has been one of the leaders amongst European producers of aluminium fire-resistant frameless partitions, windows and doorsets, ranging from **EI15** to **EI60** and walls/partitions in classes **EI15** to **EI120**.

We are in a position to meet the expectations and needs of even the most demanding client requests in the field of aluminium fire-resistant joinery.

We are ready to **cooperate** with the client at each stage of project implementation. Our service to clients covers **consultations** at the design stage, **assistance** with the determination of the scope of works, production, assembly and a full warranty.

TABLE OF CONTENTS

ALUFIRE VISION LINE | p.06

01

ALUFIRE CLASSIC LINE | p. 14

02

TECHNICAL SECTION

VISION LINE - CLASSIC LINE | p. 20

03

INTRODUCTION | p. 22

TECHNICAL DESCRIPTION AND TERMS | p. 23

ALUFIRE VISION LINE - ALL-GLASS FIRE-RESISTANT WALLS | p. 24

ALUFIRE CLASSIC LINE - MUNTIN AND MULLION FIRE-RESISTANT WALLS | p. 27

TECHNICAL FIRE-RESISTANT WINDOWS | p. 30

FIRE-RESISTANT DOORS AND WINDOWS | p. 31

HARDWARE AND ACCESSORIES OF FIRE-RESISTANT DOORS AND WINDOWS | p. 35

TYPES OF INFILLS AND COLORS APPLIED - MOUNTING | p. 42

APPROVALS AND CERTIFICATES | p. 44

QUOTATION INQUIRY | p. 46

With **Alufire Vision Line** an array of new capabilities is possible with glazing that is fire-resistant, sound suppressant and capable of reducing heat transfer.

The versatility and adaptability of Alufire glazed solutions has multiple benefits in numerous settings because of its potential to increase productivity, occupancy satisfaction and the general health of people living, working or visiting in intelligently and naturally lit locations.

Alufire glazing systems are the only LPCB glazed partition systems approved to LPS1158 — Requirements and tests for fire-resistant glazing systems — the highest form of endorsement a product can achieve.

Alufire Vision Line glazed partitions have full LPCB product certification from BRE (Building Research Establishment) guaranteeing up to 60-minutes fire performance with respect to Integrity (E) and Insulation (I) in accordance with EN 13501-2.

The European Standard EN 13501-2 has been used by BRE as the only harmonized procedure for fire resistance classification of construction products and building elements in the UK and Europe.

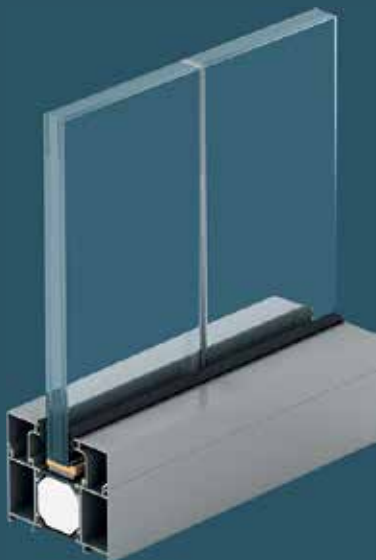



Alufire fire-rated glazing systems are an excellent way to incorporate daylighting into a building's design without compromising safety in the event of a fire.

The glazed partition units can be manufactured up to 3300 mm in height and installed in an unlimited opening width of wall, subject to the scope of certification.

The ALUFIRE system consists of fire-rated composite glass sheets secured in aluminium profiles, interconnected with a glass fibre reinforced polyamide thermal separator.

The profile chambers are filled with silicate-cement inserts and intumescent seals are included at meeting surfaces. This enables the product to provide thermal insulation and the required smoke and fire resistance that protects against the high temperatures created during a fire. Infill panels can be either glazed or opaque, dependent on client requirements.

Both AVL — **Alufire Vision Line** — and **Alufire Classic Line** are fully compatible with the Alufire single and double leaf door sets (LPCB certificate 1406b).

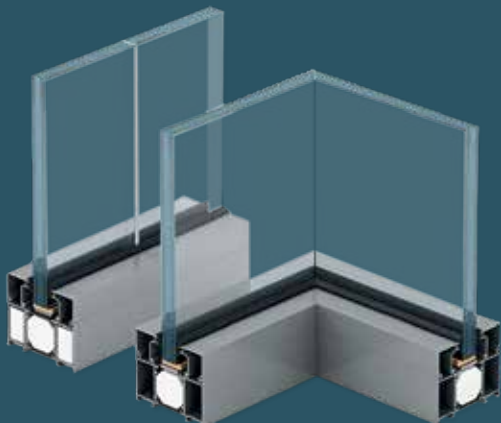



Whether you're designing or building commercial offices, a school or a healthcare facility, it is proven that controlling the transmission of sound into interior spaces increases productivity, safeguards privacy and improves the overall mood of the occupants.

In environments where noise can be a distraction, Alufire is a high-quality acoustic glass that offers excellent noise reduction without compromising on light transmittance. This enables workers to benefit from maximum daylight while avoiding the negative impact of noise pollution.

Due to the highly engineered and robust construction our systems have one of the highest acoustic coefficients on the market.



R_w up to 47 dB



Alufire Classic Line offers a system of internal and external glazing in fire-resistant classes E115 to E120. The width of the design is without restrictions and height is approved up to 4400 mm.

We applaud architecture built on innovation. At Alufire we have enhanced the relationship between form and function. Due to their stability, these systems allow architects to build entire facades out of glass, enabling design flexibility to create bright and highly attractive working environments, with more light and a greater feeling of space.

The Alufire systems are produced bespoke for your needs, delivered as complete units, for added safety and installed by our specially trained technicians.





Alufire doorsets offer a wide range of solutions for office buildings, hospitals, apartment blocks and homes.

Alufire doorsets are available as single or double leaf with fire-resistant classes EI30, EI60.

The door leaf can be manufactured up to 3241mm in height or up to 1326mm in width subject to area restrictions.

Certification includes installation into the following supporting constructions: Alufire Classic Line and Alufire Vision Line glazed systems (LPCB certificate 1406a), standard rigid (masonry), or flexible (partition) constructions.

Self-closing EN 14600 — All Alufire doorsets have the highest classification C5, subject to very frequent usage, having successfully completed in excess of 200,000 self-closing test cycles.

Smoke leakage EN 1634-3 — Alufire doorsets, on client request, are available up to the highest classification Sa — Sm.





03

TECHNICAL SECTION

VISION LINE | CLASSIC LINE

CLASSIC LINE DOORS

Alufire offers fire-resistant joinery in two systems - muntin and mullion **Alufire Classic Line** and the all-glass **Alufire Vision Line**.

The all-glass **Alufire Vision Line (AVL)** wall system has the best noise reduction ratio in the market:

- AVL Standard **$R_w=39$ dB**, ($R_{A1}=37$ dB and $R_{A2}=35$ dB)
- AVL Acoustic **$R_w=44$ dB**, ($R_{A1}=43$ dB and $R_{A2}=39$ dB)
- AVL Acoustic+ **$R_w=47$ dB**, ($R_{A1}=45$ dB and $R_{A2}=42$ dB)

The **Alufire Classic Line** system is characterized by the following features:

- **sound reduction:**

- of doors (glass) **$R_w=42$ dB**, ($R_{A1}=41$ dB and $R_{A2}=39$ dB)
- of internal walls **$R_w=41$ dB**, ($R_{A1}=41$ dB and $R_{A2}=38$ dB)
- of external walls **$R_w=44$ dB**, ($R_{A1}=43$ dB and $R_{A2}=40$ dB)
- of doors (panel) **$R_w=38$ dB**, ($R_{A1}=38$ dB and $R_{A2}=36$ dB)
- aluminium fire-resistant EI30 and EI60 doors correspond to class 4 of strength

requirements according to EN 1192:2001 i.e. conditions of heavy and very heavy-duty operation

- segments of fire-resistant walls of a maximum height of 4000 mm for classes from EI15 to EI60 and 4200 mm for class EI120 unlimited length, with (the application of dilatation every 8000 mm) and mullions spacing, depending on maximum dimensions of infills (glazing or panel) fulfil the requirements set out for the category IV of use, according to the guidelines for the European Technical Approval ETAG No. 003.

The glazing and non-transparent infills applied in the ALUFIRE system fulfil the requirements imposed on the corresponding classes of fire resistance.

In addition, in the ALUFIRE system, seals expanding under the impact of temperature are applied, which ensures tightening of the joinery in the case of fire, preventing the smoke and fire from getting inside through the partition.

INTRODUCTION

TECHNICAL DESCRIPTION AND TERMS

Alufire manufactures single- and double-leaf doors, fixed walls with and without cross-bars, side-hung casement windows and connections for opened elements with fixed walls in various configurations and in different classes of fire resistance EI15, EI30, EI45, EI60 and EI120, as well as smoke leakage performance (EN 1634-3) up to Sa - Sm.

Our products are made of aluminium profiles joined by a thermal break made of polyamide, reinforced with glass fibre, which makes up a three-chambered profile. Owing to the application of thermal breaks and filling the profiles chambers with silicate-cement inserts, thermal insulation is maintained during a fire. The number of chambers filled is dependent upon the class of fire resistance of the given element.

Glass panes and non-transparent/solid panels are used as infills for doorsets, windows and fixed walls. The glass **panes** are composed of **several** layers of glass which are separated by layers of gel. In case of fire on one side, both glazing and/or infills which fill the profiles are insulating barrier preventing the second side from reaching an average temperature of above 140 °C.

The following classes for Alufire fire-resistant doorsets are available: EI15, EI30, EI45, EI60, including smoke leakage classification up to S and Sa - Sm. The Sa - Sm classification means that the partition can resist the passage of smoke whilst retaining its fire integrity (E) and fire Insulation (I) for 60 minutes.

Integrity (E) is the ability of the element of construction that has a separating function, to withstand fire exposure on one side only, without the transmission of fire and hot gases to the unexposed side. In that case the ignition of any adjacent material or surface may happen

on unexposed side due to transmission of temperature.

Insulation (I) is the ability of the element of construction to withstand fire exposure on one side only, without the transmission of fire and with limited transmission of heat so that neither the unexposed surface nor any material in close proximity to that surface is ignited. The element is also sufficient barrier to protect people near to it.

Smoke leakage (S) is the ability of the element to reduce or eliminate the passage of gases or smoke from one side of the element to the other.

Sa considers smoke leakage at ambient temperature only.

Sm considers smoke leakage at both ambient temperature and at 200 °C.

Self-closing (C) is the capacity to release the opened door and window installations and to ensure the reliable closing of the leaves/sashes in the case of fire and smoke. To fulfil the above condition, i.e. security against fire and smoke, all the elements to be opened are equipped with self-closing devices, referred to as self-closers.

If a fire-resistant door is mounted on evacuation routes, it is required to be installed with anti-panic hardware/furniture. The requirements for this type of hardware are laid down in the following standards: EN 179:2009 and EN 1125:2009. These standards set out the requirements related to the hardware production, operation and testing for emergency exit doors with two solutions being taken into account:

- emergency closers for exit started by a handle or pressure plate,
- anti-panic closers for exit started by a horizontal bar (lever or anti-panic strip).

ALUFIRE VISION LINE ALL-GLASS FIRE-RESISTANT WALLS

THE FIRST POLISH SYSTEM OF FIRE-RESISTANT ALL-GLASS WALLS IN CLASSES EI30 AND EI60.

The frameless system utilises laminated fire-resistant glass, owing to which the gap between the panes filled with non-flammable silicone is limited to the total width of the non-transparent strip, ranging from only 4 to 6 mm.

For comparison, other available systems apply fire-resistant toughened glass where a non-transparent strip of as much as 30mm occurs.

The AVL system has the best sound reduction ratio on the Polish market, R_w up to 47 dB and it is certified to be installed in C and D category premises and, in accordance with ETAG 003, may be mounted on the edges of ceiling which allows safe access and evacuation of by people from upper floors.

The all-glass AVL system has the following R_w parameters - only for single pane:

- AVL Standard $R_w = 39$ dB, ($RA_1 = 37$ dB and $RA_2 = 35$ dB)
- AVL Acoustic $R_w = 44$ dB, ($RA_1 = 43$ dB and $RA_2 = 39$ dB)
- AVL Acoustic+ $R_w = 47$ dB, ($RA_1 = 45$ dB and $RA_2 = 42$ dB)

The difference in sound reduction depends upon the glazing applied. In the case of AVL Acoustic and AVL Acoustic+ walls, a special glass of higher sound reduction parameters and thickness is applied.

The width of walls is not limited and the height, depending upon the version may reach as much as 3.3 m. Angle and T type connections are made on the principle: "glass to glass" without the application of any additional cover strips.

Figure 1. Total width of non-transparent strips on connections of layered pane of Alufire Vision Line (A) and toughened panes of other systems (B) - comparison.

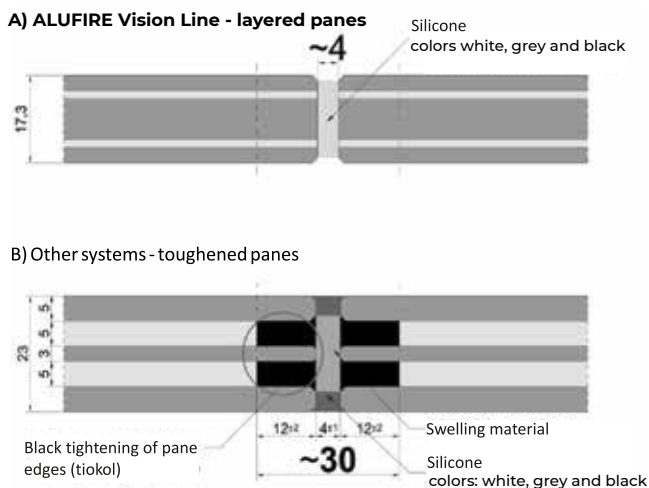

To maintain the cohesive appearance of the construction mounted close to each other, we can construct all glass walls with non-fire-resistant panes in places where no fire resistance is required. ALUFIRE fire-resistant system doors, and non-fire-rated wooden or glass doors can be a supplement to the wall.

Glass fire-resistant walls of Alufire Vision Line give unlimited visual possibilities to increase the interior and to bind it to the remaining space, at the same time maintaining fire-resistant safety.

NOTE: Because of their complexity, all-glass Alufire Vision Line walls are mounted only by authorised ALUFIRE installers.

Table 1. Maximum dimensions of AVL walls

Maximum dimensions of ALUFIRE Vision Line walls	
Wall height [mm]	2988 / 3034*
Wall height [mm] - unit release	3300*
Width of single glazing module EI30 [mm]	1000
Width of single glazing module EI30 [mm] - unit release	1920
Width of single glazing module EI60 [mm]	1200
Width of walls	unlimited

Higher glass walls may be manufactured subject to provision of further test evidence.

All-glazed fire resistant walls of ALUFIRE Vision Line have Technical Approval No AT-15-9439/2015 and also Building Research Establishment LPCB British certification



LPCB Certificate Number: 1406a

ALUFIRE Vision Line was awarded a prize at the "Good Design" competition by the Institute of Industrial Designs in Warsaw.



You can find more information and a gallery of photos on the following website: www.alufire.com/en/vision-line/

Figure 2. Connections in AVL constructions



“pane to pane” connection



“pane to pane” angle connection

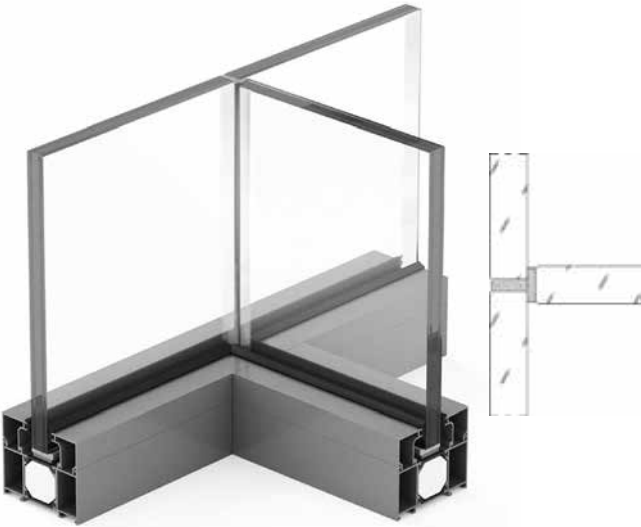

“pane to pane” T connection

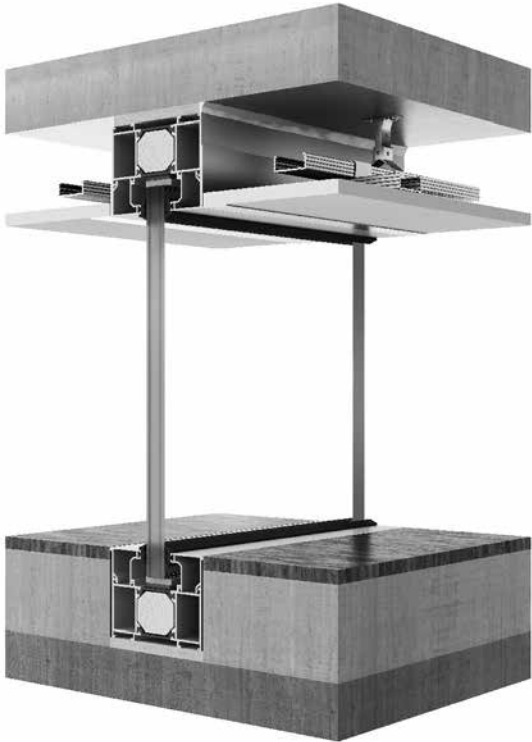

hidden AVL profile

Figure 3. Examples of non-typical AVL construction shapes

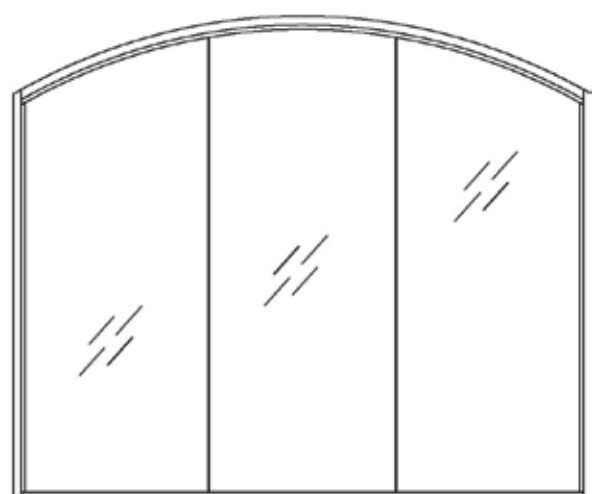
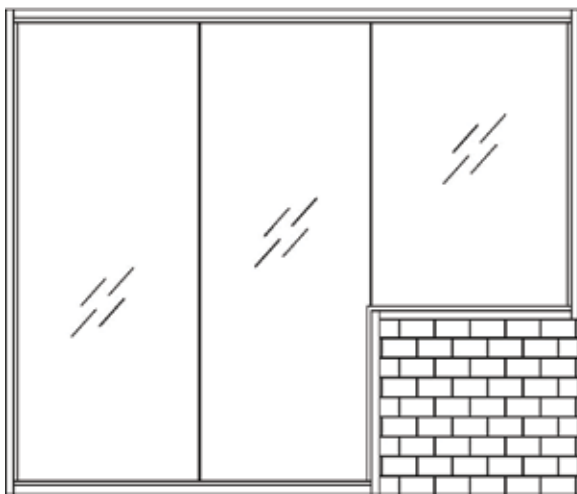
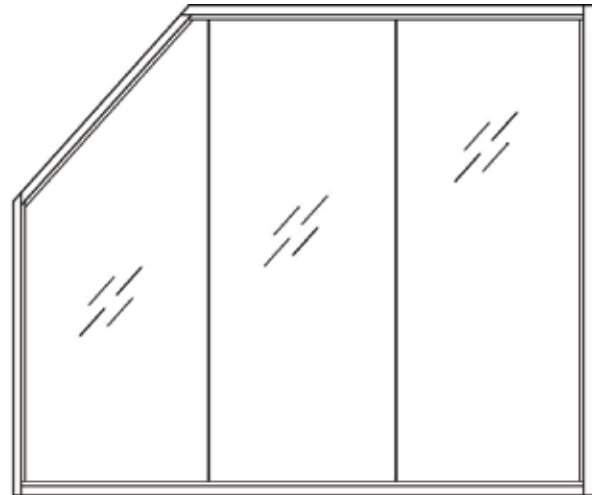
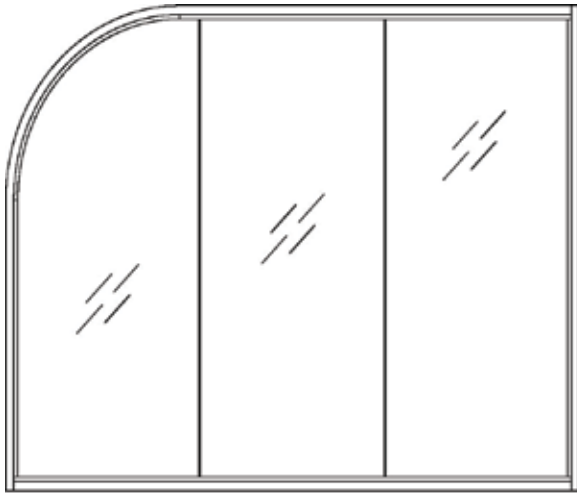

Figure 4. Examples of angle connection of AVL construction -horizontal cross-section through designed wall with doors

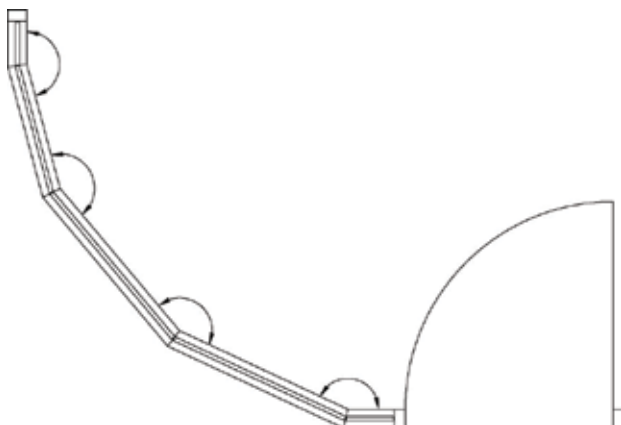

Photo 1. The above example of angle wall is an alternative for expensive constructions with bent glass. An additional value of such a solution is no deformation of the image when compared to the bent glass.

ALUFIRE CLASSIC LINE

MUNTIN AND MULLION FIRE-RESISTANT WALLS

The maximum dimensions of the fixed walls are laid down by Technical Approval No AT-15-6520/2016. Fixed walls with doors or without them may have a maximum height of 4200 mm. The width of walls is not limited provided that dilatation every 8000mm is applied, whereby

the spacing of mullions for internal and external joinery depends upon types of glazing and infills. **(Table 2).**

ALUFIRE makes fixed walls in fire resistance classes EI15, EI30, EI45, EI60 and EI120.

Figure 5. Dimensions of fixed walls with or without doors

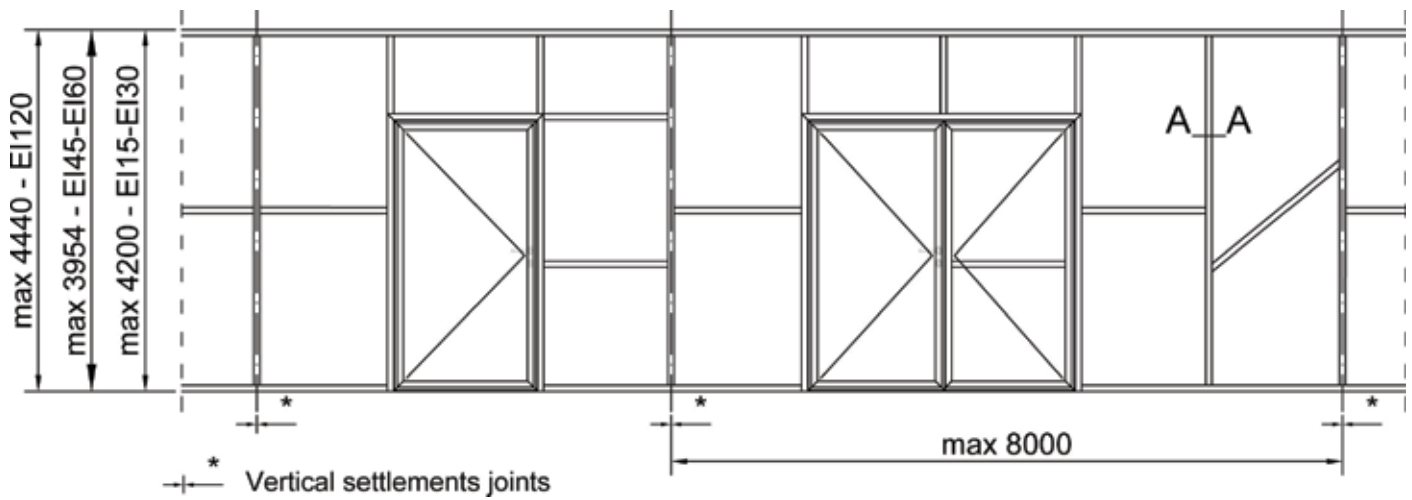
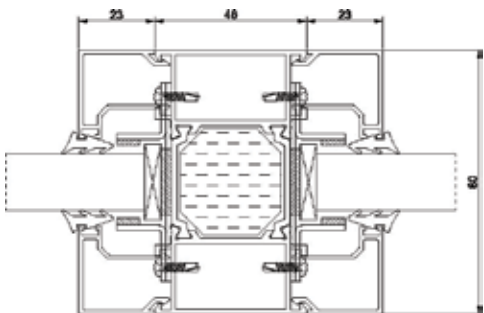

Figure 6. Horizontal cross-section through the internal wall (W) and external wall mullions (Z) - EI30, EI60

A - A | EI30



W: single glass

A - A | EI60

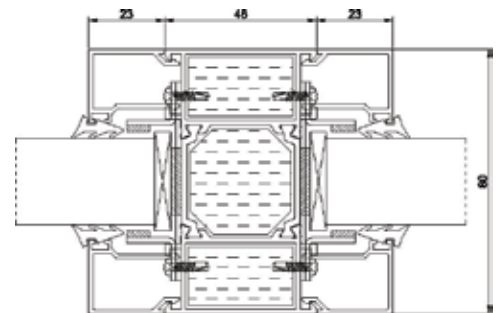

Z: insulated glass

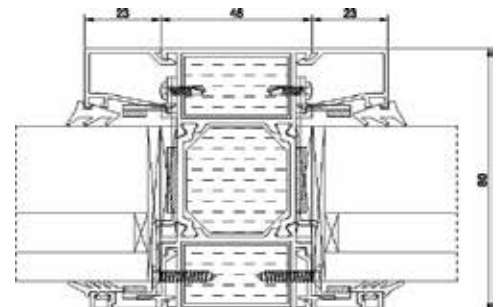
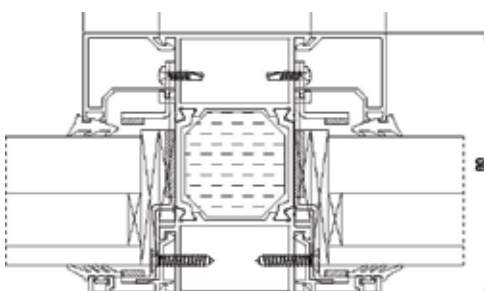
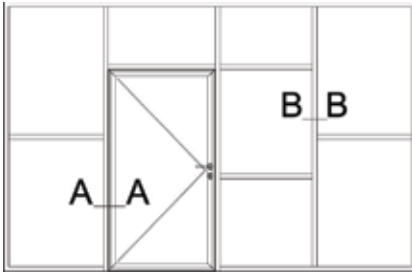

Table 2. Glass applied in ALUFIRE Systems

Pos.	Manufacturer	Glass pane type	Used in non-loadbearing walls system ALUFIRE	Thickness [mm]	Max. dimensions in portrait orientation (width x height) [mm]	Max. dimensions in landscape orientation (width x height) [mm]
1.	AGC	Pyrobel 8	EI15	9,3	1400 x 2500	2500 x 846
2.	AGC	Pyrobel 8EG	EI15	13,1	1400 x 2500	2500 x 846
3.	PILKINGTON	PYRODUR 30-103	EI15	9	1400 x 2500	2500 x 846
4.	PILKINGTON	PYRODUR 30-201	EI15	10	1400 x 2500	2500 x 846
5.	AGC	Pyrobel 16	EI15, EI30	17,3	1540 x 2750, at maximum area 3,87 m ²	2750 x 931, at maximum area 2,34 m ²
					1000 x 2888	
6.	AGC	Pyrobel 16EG	EI15, EI30	21,1	1400 x 2500	2500 x 846
					1000 x 2888	
7.	AGC	Pyrobel 17	EI15, EI30	17,8	1400 x 2500	2500 x 846
					1000 x 2888	
8.	AGC	Pyrobel EI30/16	EI15, EI30	16	1148 x 2225	1148 x 2225
9.	PILKINGTON	PYROSTOP 30-10	EI15, EI30	15	1680 x 3000, at maximum area 4,24 m ²	3000 x 1015, at maximum area 3,75 m ²
10.	PILKINGTON	PYROSTOP 30-20	EI15, EI30	18	1400 x 2500	2500 x 846
11.	REGLAS S.r.o	PYROBAT 15	EI15, EI30	15	1127 x 2050	2050 x 1127
12.	PILKINGTON	PYROSTOP 30-10	EI45	15	1123 x 2223	1123 x 2223
13.	PILKINGTON	PYROSTOP 30-20	EI45	18	1100 x 2000	1100 x 2000
14.	PILKINGTON	PYROSTOP 60-101	EI45, EI60	23	323 x 2700	2500 x 1300
					1500 x 2500	
15.	PILKINGTON	PYROSTOP 60-201	EI45, EI60	27	323 x 2700	2500 x 1300
					1500 x 2500	
16.	VETROTECH SAINT GOBAIN	CONTRAFLAM N2	EI45, EI60	23	1146 x 2223	1146 x 2223
17.	GLASS TEAM	POLFLAM EI60	EI45, EI60	34	1423 x 2223	1423 x 2223
18.	AGC	PYROBEL 25	EI45, EI60	26,6	1200 x 3465, at maximum area 3,49 m ²	2500 x 846
					1400 x 2500	
19.	AGC	PYROBEL 25EG	EI45, EI60	30,4	1000 x 2888	2500 x 846
					1400 x 2500	
20.	PILKINGTON	PYROSTOP 120-10	EI120	58	1702 x 2662, at maximum area 3,81 m ²	2662 x 1582, at maximum area 3,54 m ²
21.	PILKINGTON	PYROSTOP 120-380	EI120	64	1320 x 2440, at maximum area 2,94 m ²	2440 x 693, at maximum area 1,54 m ²
22.	ALUFIRE	Non-transparent panel	EI15, EI30	28	1800 x 3000, at maximum area 4,54 m ²	1800 x 3000, at maximum area 4,54 m ²
23.	ALUFIRE	Non-transparent panel	EI45, EI60	40,5	1500 x 2500	1500 x 2500
24.	ALUFIRE	Non-transparent panel	EI120	62	1324 x 2400, at maximum area 2,71 m ²	2274 x 763, at maximum area 1,46 m ²

Figure 7. Cross-section through mullion of internal wall (W) and external wall (Z) of EI120 fire-resistant wall EI60 door



A - A

B - B

W

W

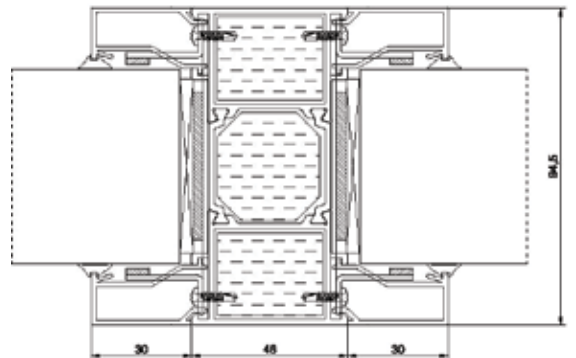
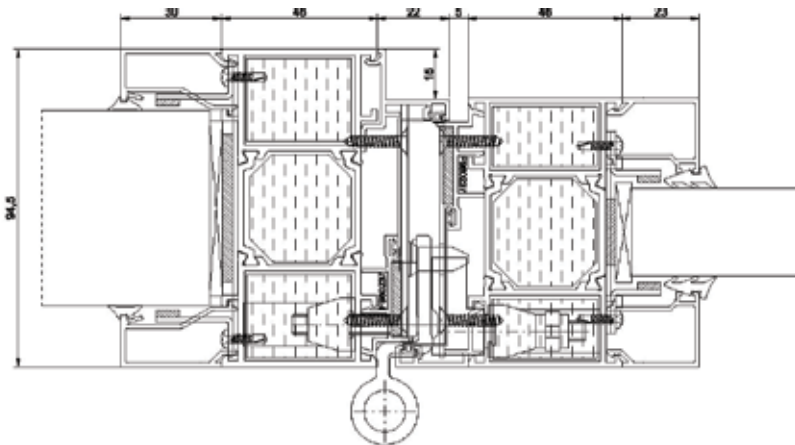

Z

Z

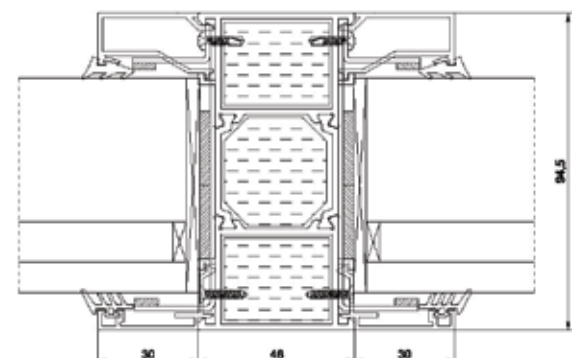
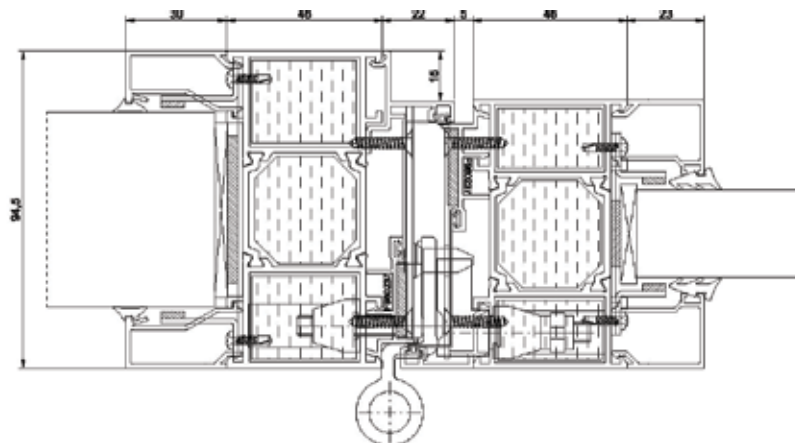

TECHNICAL FIRE-RESISTANT WINDOWS

The whole construction is manufactured in the door system - the frame runs along the whole circumference of the window (there is no threshold). We manufacture only side-hung windows without the function of bottom-hung windows. The minimum dimensions of window construction are 600x600 mm. For windows, we apply furniture / hardware designated for production of doors, i.e. a lock with an insert and a half-handle, three-part hinges per door leaf and a self-closer.



Photo 2. Window GEZE K600 F air vent.

We also produce air-vent windows -with pushers- in such a case, the window is not equipped with self-closure. The function of opening or closing is fulfilled by the GEZE K600 F air vent, connected to the fire resistant center (**Photo 2**).

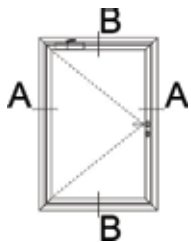
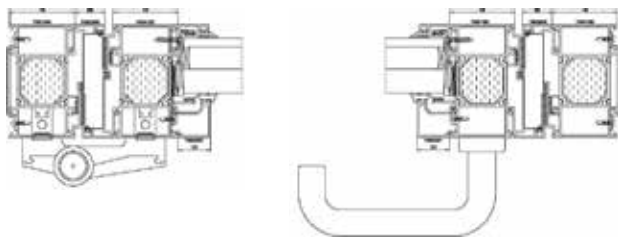

Figure 8. Horizontal cross-section of EI30 window (similar to EI15 and EI60)

A - A



NOTE: In the windows, inter-glaze dividers may be applied 8, 18, 26, 45 mm wide in any RAL color (examples of windows and walls with intra-glazing dividers are presented in **Photo 3**).

Figure 9. Vertical cross-section for EI30 (similar to EI15, EI45 and EI60)

B - B

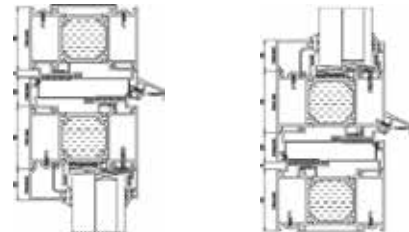

NOTE: Pursuant to the fire resistance provisions, a fire-resistant window must be equipped with a self-closer.



Photo 3. ALUFIRE fire resistant technical window with a fixed wall (intra-glazing dividers)

Figure 10. Exemplary detail of window with still joining

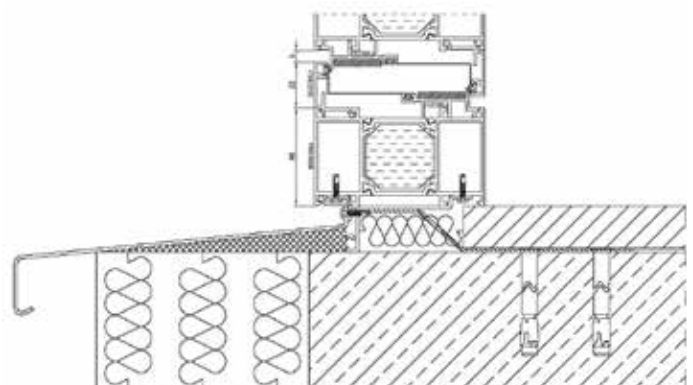

FIRE-RESISTANT DOORS AND WINDOWS

TECHNICAL PARAMETERS

The ALUFIRE system doors are characterized by very high mechanical strength, meeting **class 4**: i.e. heavy to very heavy operations, according to standard EN 1192:2001 and they have the highest class of mechanical durability: **C5** (200000 cycles of opening and closing) according to EN 14600:2009 standard. Having obtained such high strength parameters and mechanical durability enables the application of the ALUFIRE system doors in public facilities such as offices, governmental authorities, schools, hospitals, dispensaries, hotels and warehouses, as well as production plants with a high or very high intensity of traffic.

The aluminium profiles can be protected against corrosion or by powder coating or anodic oxidation, which ensures the best class of anti-corrosion resistance of protective coat **C4** for Alufire systems according to standards EN ISO 12944-2:2001.

The maximum dimensions for the ALUFIRE system doors are laid down in Technical Approval No. AT-15-6520/2016. They are presented in **Figure 11**.

Moreover, ALUFIRE doors and windows are approved fulfil requirements of classes EI₁ and EI₂.

a) Dependencies between the width of the clear door, the external dimension and the width of the opening in the wall. The below figures are calculated for the door open at 90° position

b) Dependencies between the height of the clear door opening, the external dimension and the height of the opening in the wall for the single and double-leaf doors

Single-leaf doors

Width of clear door opening S_p [mm]	External width of joinery S [mm] $S_p + 220$ [mm]	Width of the opening in the wall S_o [mm] $S_p + 250$ [mm]
800	1020	1050
900	1120	1150
1000	1220	1250
1100	1320	1350
1200	1420	1450

Double-leaf doors

Width of clear door opening S_p [mm]	External width of joinery S [mm] $S_p + 220$ [mm]	Width of the opening in the wall S_o [mm] $S_p + 250$ [mm]
1060	1360	1390
1100	1400	1430
1200	1500	1530
2200	2500	2530

Doors without a threshold

Height of clear door opening H_p [mm]	External height of joinery H [mm] $H_p + 70$ [mm]	Height of the opening in the wall H_o [mm] $H_p + 90$ [mm]
2000	2070	2090
2100	2170	2190
2200	2270	2290
2680	2750	2770

Doors with a low threshold of 10mm to be used inside

Height of clear door opening H_p [mm]	External height of joinery H [mm] $H_p + 70$ [mm]	Height of the opening in the wall H_o [mm] $H_p + 90$ [mm]
2000	2080	2100
2100	2180	2200
2200	2280	2300
2670	2750	2770

Doors with a high threshold of 20mm to be used outside

Height of clear door opening H_p [mm]	External height of joinery H [mm] $H_p + 70$ [mm]	Height of the opening in the wall H_o [mm] $H_p + 90$ [mm]
2000	2090	2110
2100	2190	2210
2200	2290	2310
2660	2750	2770

NOTE: dimensions for door open on 90° position

Figure 11. Maximum dimensions of technical doors and windows - EI30, EI60 [mm]

EI30

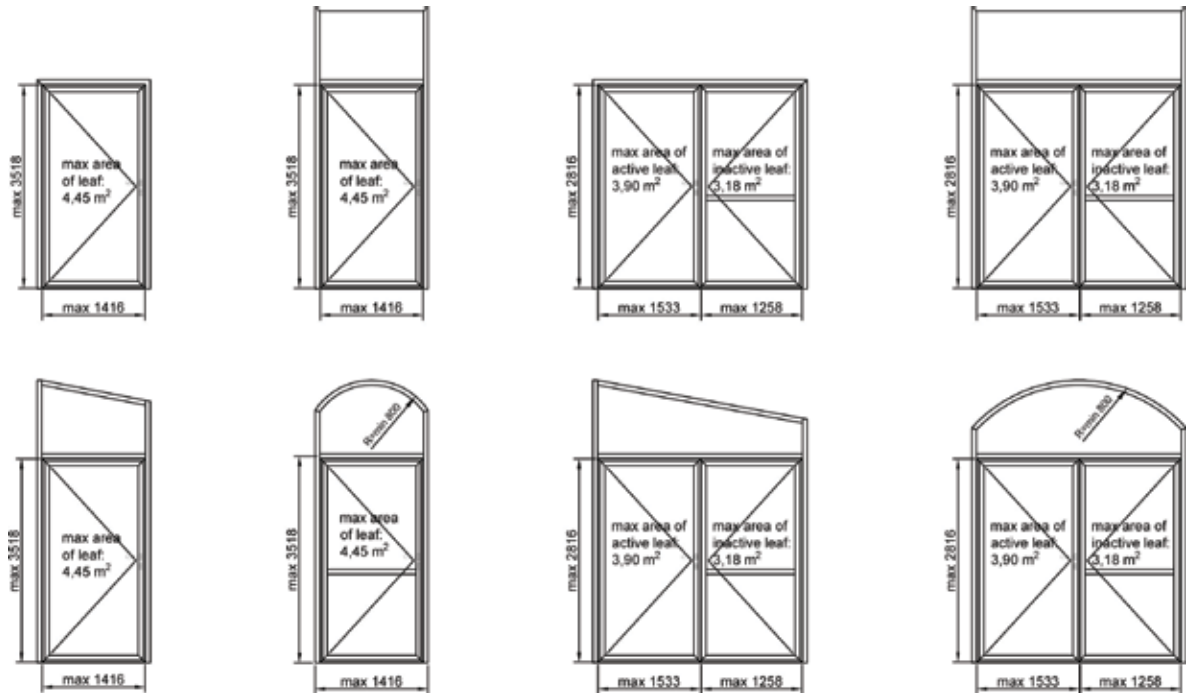

EI60

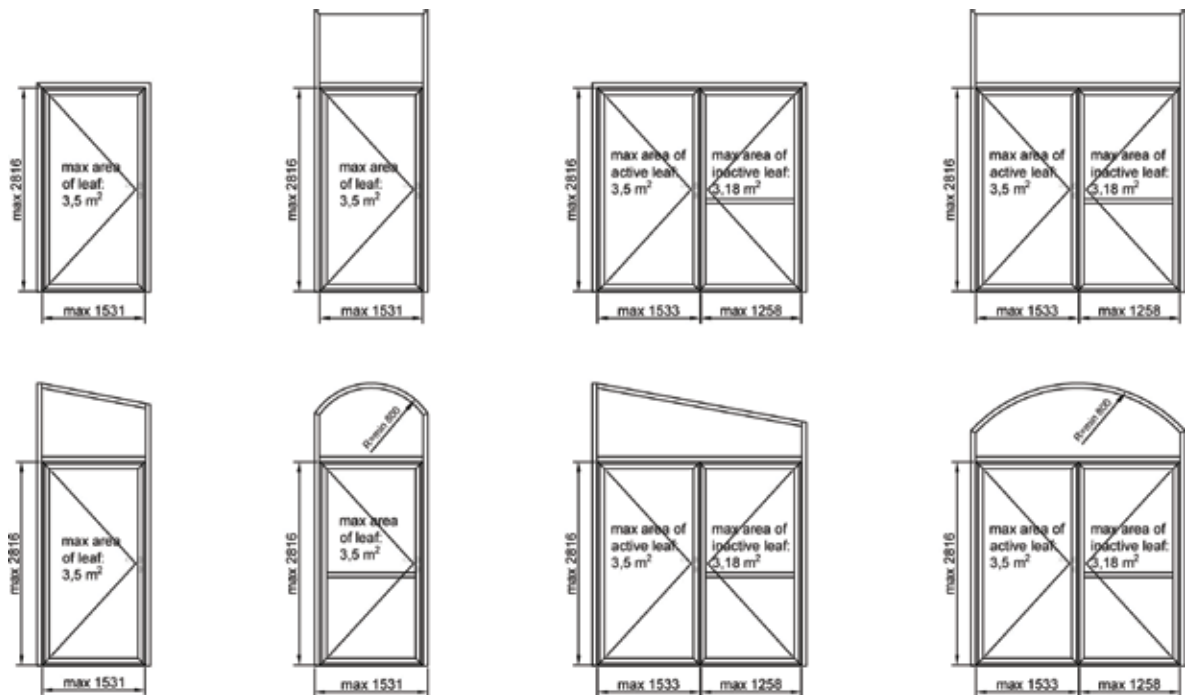

NOTE: In the case of constructions larger than those released in the Technical Approval, they can be manufactured pursuant to an

opinion or individual admission. All matters related to exceeded maximum dimension: consulted with ALUFIRE Distributor.

Figure 12. Horizontal cross-section of fire-resistant single leaf EI30 doors (similar to EI15, EI45 and EI60)

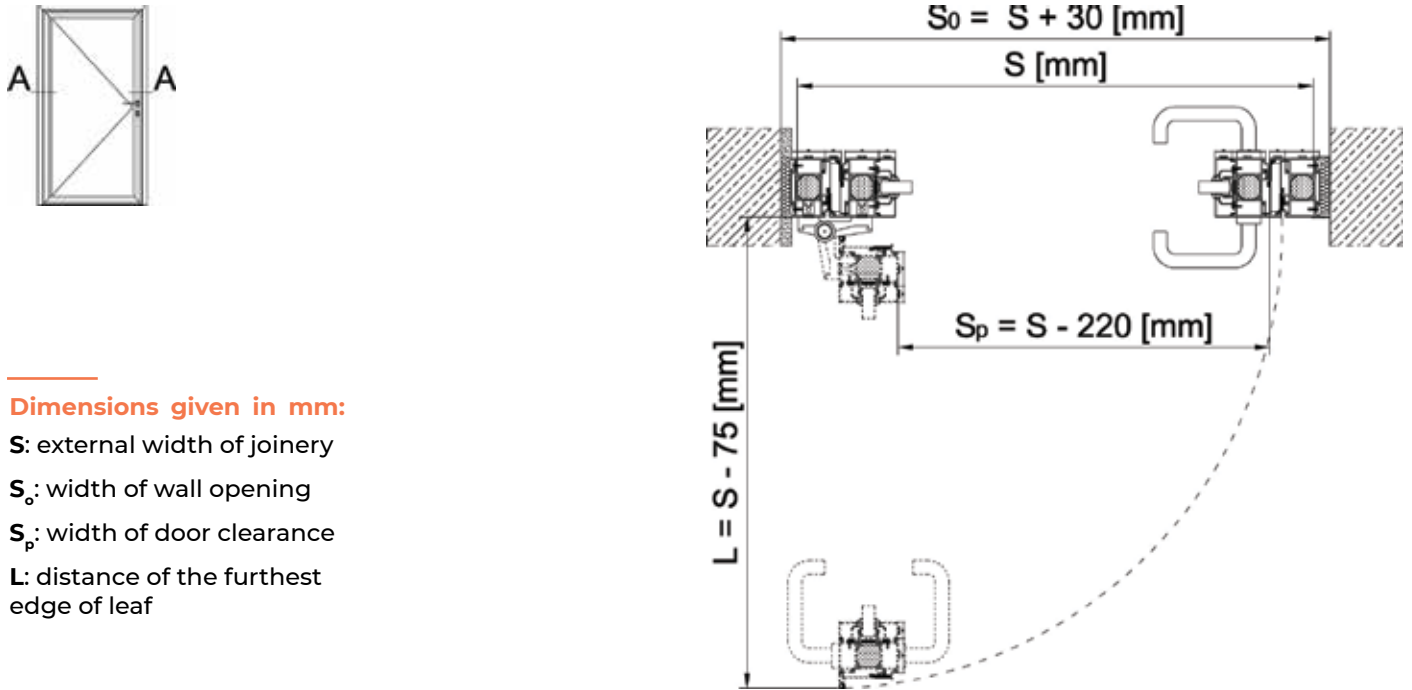

Dimensions given in mm:

- S: external width of joinery
- S₀: width of wall opening
- S_p: width of door clearance
- L: distance of the furthest edge of leaf

Figure 13. Horizontal cross-section of fire-resistant double leaf EI30 doors (similar to EI15, EI45 and EI60)

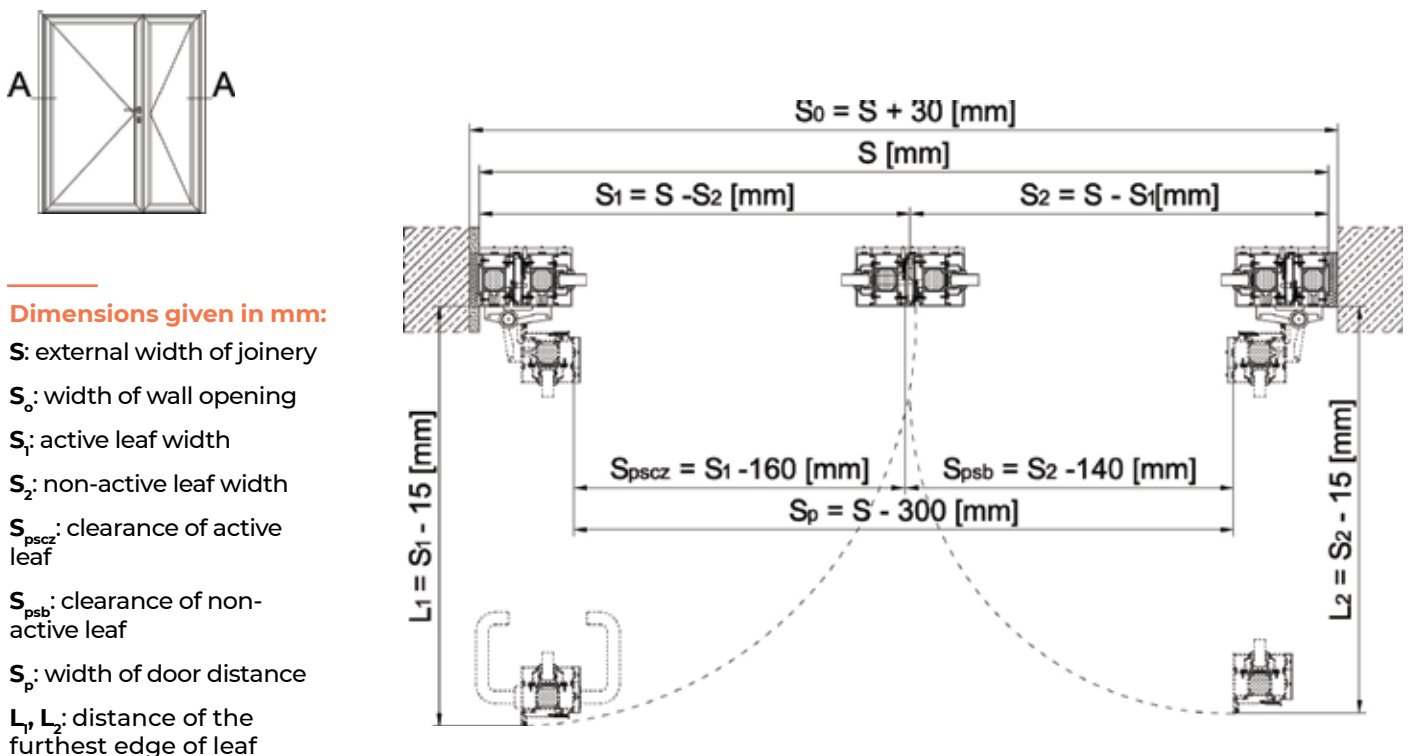

Dimensions given in mm:

- S: external width of joinery
- S₀: width of wall opening
- S₁: active leaf width
- S₂: non-active leaf width
- S_{p_scz}: clearance of active leaf
- S_{p_sb}: clearance of non-active leaf
- S_p: width of door distance
- L₁, L₂: distance of the furthest edge of leaf

Dimensions given in mm:

H: external height of joinery

H_o: wall opening height

H_p: door clearance height

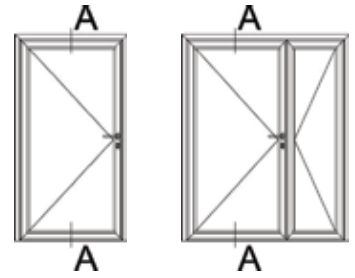

a) **A - A**

Without threshold

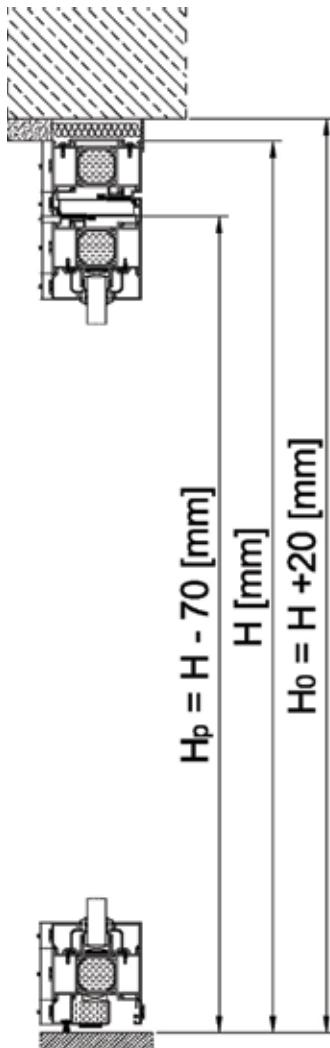

b) **A - A**

With low threshold

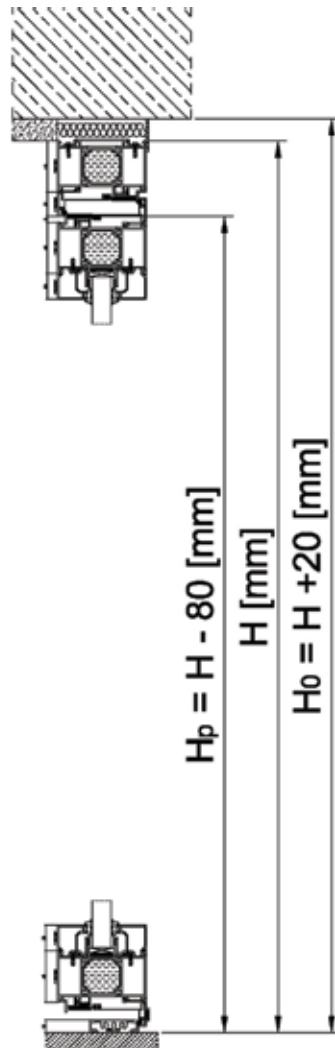

c) **A - A**

With high threshold

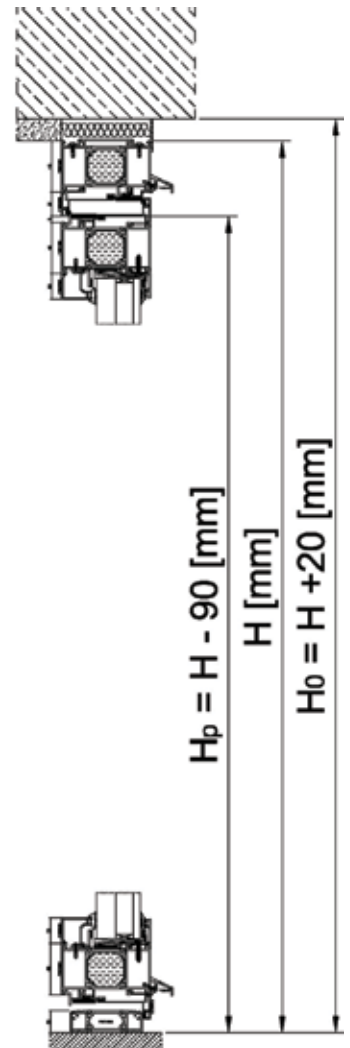

HARDWARE AND ACCESSORIES OF FIRE-RESISTANT DOORS AND WINDOWS

Fire-resistant doors are equipped with a bolt-catch lock with a lock insert, a U-form safe handle made of stainless steel, three-part hinges per door leaf and a self-closer, as standard. Below is shown hardware which are most popular in

Polish, British, Czech and Lithuanian markets. There is also possibility to apply other hardware, which is more typical for particular market on condition that is certified as fire-resistance.

HANDLES AND DOORKNOBS

The stainless-steel handle, of U-form and L-form types, comes with an oval divided rosette and a fixed doorknob to control the access on one side. Assembly of the rosette, handle and doorknob takes place with the use of rivet nuts.



Photo 4. Handle and fixed doorknob

SELF - CLOSERS

The self-closers shall be assembled exclusively with the help of **rivet nuts**.



Photo 5. GEZE TS 2000 self-closer

- three basic colors: white, silver and brown
- adjustable power of closing 2/3/4/5
- adjustable speed of closing and final pressure
- delayed opening action
- mounting to the left and right doors on the side of hinges and on the opposite side
- alternative optional DORMA GROOM GR 200



Photo 6. GEZE TS 4000 self-closer

- three basic colors: white, silver and brown
- smooth adjustable power of closing 2-5, adjusted by hydraulic valve
- adjustable speed of closing and final pressure
- delayed opening action
- mounting to the left and right doors on the side of hinges and on the opposite side
- alternative optional DORMA TS 83



Photo 7. GEZE TS 5000 self-closer

- three basic colours: white, silver and brown
- no grading in the closing power 2-5, adjusted by hydraulic valve
- three speeds of closing, adjusted by hydraulic valves
- mounting to the left and right doors
- mounting on the door-leaf on the side of hinges
- TS 5000 S with adjusted function of delayed closing
- TS 5000 E with built in electromagnetic retainer in a rail
- TS 5000 R with electromagnetic retainers and smoke sensor integrated in a rail
- optionally DORMA TS 93



Photo 8. GEZE TS 5000 self-closer together with rail

- three basic colors: white, silver and brown
- no grading in the closing power 2-5, adjusted by hydraulic valve
- three speeds of closing, adjusted by hydraulic valves
- mounting to the left and right doors
- mounting on the door-leaf on the side of hinges
- TS 5000 ISM with integrated adjustor of the sequence of closing
- TS 5000 E-ISM with integrated adjustor of the sequence of closing and electromagnetic retainers in the rail
- TS 5000 R-ISM with integrated adjustor of the sequence of closing, electromagnetic retainers and smoke sensor in a rail
- optionally DORMA TS 93



Photo 9. "Hidden" self-closer of GEZE company BOXER type

The self-closer for assembling in the door construction is completely hidden in the leaf and frame profile. The closing force is in accordance with the guidelines of EN 1154 standard. The speed of closing, the functions of end stop and mitigating closing are adjusted hydraulically with the use of screws available also after assembling in the leaf. Self closer may be applied in doors of a leaf weight up to 130 kg.

ELECTROMAGNETIC DOOR RETAINER

In particular cases, when it is necessary to keep the leaves permanently open, an electromagnetic door retainer connected to SAP system shall be used. We apply the following types of door retainers:

- wall-mounted point door retainer
- floor-mounted point door retainer
- retainer integrated in the slip rail of self-closer

Figure 14. Place of wall-mounted electromagnetic door retainer

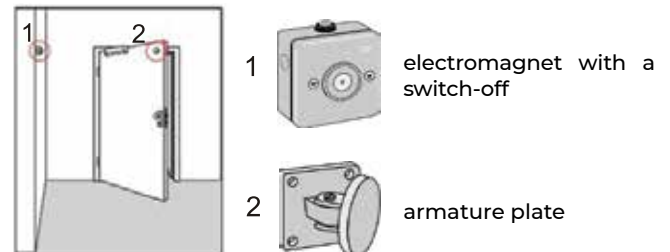

ACCESS CONTROL

- a) Single-sided/averse electric strike
- single-sided access control
 - hardware: handle - knob
 - closed without electric current NC
 - mounting next to the main lock
 - supply 12+24V DC
 - optional electric strike with monitoring

- a) Double-sided/reverse electric strike
- double-sided access control
 - hardware: handle - handle
 - open without electric current NO
 - mounting next to the additional lock
 - suggested mounting in emergency escape doors
 - supply 12 or 24V DC
 - optional electric strike with monitoring



- b) Electromagnetic dead bolt
- double-sided access control
 - hardware: handle - handle
 - open without electric current NO
 - surface mounting
 - suggested mounting in emergency escape doors
 - supply 12 or 24V DC



- c) Electric locks
- single-sided access control - lock type EL460
 - double-sided access control - lock type EL461
 - adjusted side of escape handle - lock type EL 460
 - unlocking the lock with the use of a key, magnetic card, coder, etc
 - working mode NC/NO
 - supply 12 ÷ 24 V DC
 - monitoring functions:
 - bolt position
 - trigger position
 - handle position
 - key position



CLOSING SEQUENCE ADJUSTOR

Closing sequence adjustor for doors serves to ensure the correct sequence of leaf door closing. It is applied when both leaves are open and their closing is controlled remotely with the use of electromagnetic retainers or anti-panic door hardware.

We can distinguish two types of closing sequence adjustor: lever adjustor (**Figure 15**) and one integrated in the slip rail of self-closure (**Photo 8**). When applying the lever closing sequence adjustor, self-closures are applied on both leaves.

Figure 15. Lever closing sequence adjustor

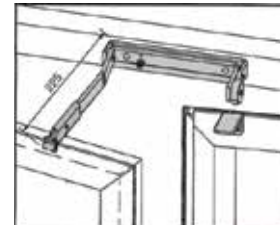

ANTI-PANIC DEVICES

Emergency closures for exits started with a handle are applied in buildings whose users are familiar with the facility and the security systems applied, the action of emergency closures included and the breakout of panic is deemed to be possible. In other cases, anti-panic closures are applied to exits, started with a horizontal “pressure rod” or a “pressure strip”.

Anti-panic closures make it possible to remove people with minimum effort and without any earlier knowledge of the device’s functioning, which means acting on reflex. The basic requirement imposed on this hardware is that the doors should be easy to open for inexperienced people, as well as the elderly and the handicapped.

For single-leaf doors, anti-panic hardware is applied, blocked in one point and for smoke-resistant doors, hardware blocked in three points is applied, which improves the smoke resistance of such construction. In double-leaf doors, the passive leaf is always blocked in two points (top and bottom) and the active leaf, similarly to the single-leaf doors, in one or three points, for smoke-resistant doors.

The access control in a door with anti-panic hardware is possible through the application of a reverse electric strike or an electromagnetic dead bolt. In this case, there is no need to apply an additional element to cut off the voltage from the inside of the door, as the anti-panic hardware is equipped with a contractor, cutting off the voltage from the system of access control.

Figure 16. Examples of anti-panic hardware and number of points of leaf blocking

a) standard door

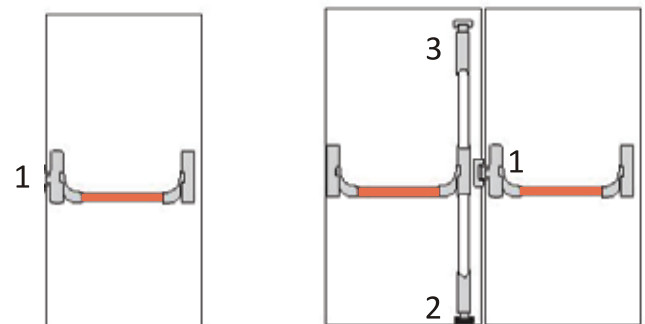

b) smoke-resistant door

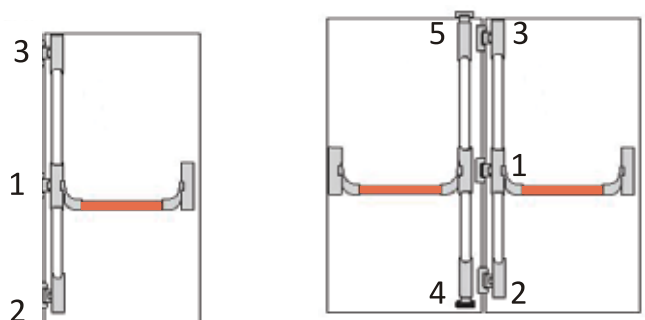

SMOKE RESISTANT DOORS

Smoke resistant doors in the ALUFIRE system, over 2300 mm high, are equipped with a three-point rod lock instead of a standard bolt-catch lock.

The application of such a solution shall cause a better tightness of the door. In addition, from the bottom of the door leaves, we apply an automatically dropping seal which additionally seals the space between the leaf and the floor and protects against smoke getting into the premises.

Such doors may be equipped with an access control in the form of reverse electric strike or electromagnetic deadbolt.

The application of the reverse electric strike is not possible because the lock has three catches.

AUTOMATIC SLIDING DOORS

ALUFIRE offers an alternative for fire resistant automatic sliding doors.

This solution consists in a parallel connection of the automatic sliding door without fire resistance and the fire resistant side-hung door with anti-panic hardware and electromagnetic retainers.

The system of this solution is presented in **Figure 18**.

Figure 17. Vertical cross-section through the bottom profile of smoke resistant door with an automatically dropping seal

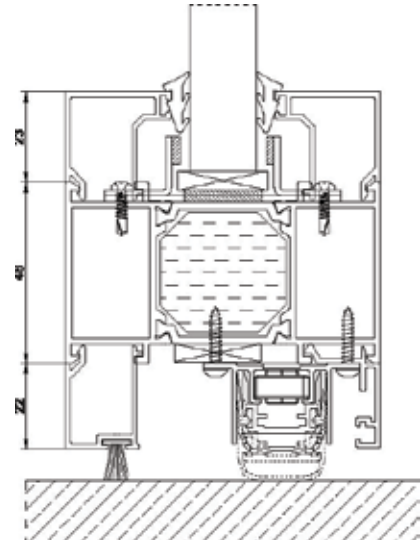
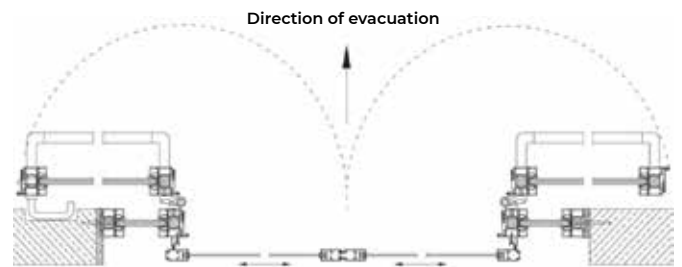
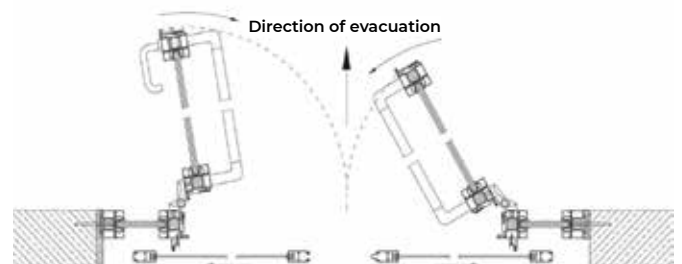

Figure 18. Solution for sliding fire-resistant door construction



Door system during normal operation
 -sliding door closed, opened automatically with a motion sensor
 -fire-resistant door open (electromagnetic retainers)



Door system during fire alarm
 -sliding door starts to open
 -after the retainers are released, fire-resistant door closes (first the passive leaf, then, the active leaf)

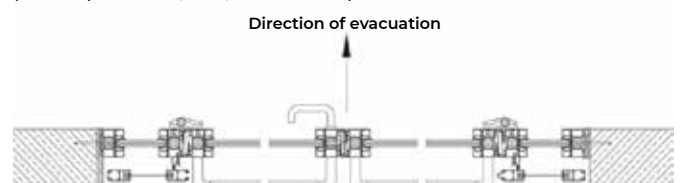

Door system during fire (evacuation)
 -sliding door opened permanently
 -fire-resistant door closed automatically, but may be opened manually with an anti-panic lever

SIDE-HUNG DOORS OPENED AUTOMATICALLY

Side-hung doors opened automatically are applied most frequently in the places with high movement intensity, in health care buildings, commercial centres, etc. The application of averse electric strike allows to open the door using automation system without having to press the handle and release the lock catch.

The automation system is connected to the averse electric strike which releases the leaf at the moment the automation system starts to operate. After the leaf has been opened, the voltage is cut off the automatic electric strike, which causes its closed position.

A few devices that open the automation

system can be connected to it, for instance: a motion sensor, an automatic opening button or a magnetic card reader. The type of devices applied depends upon the investor's needs and the functionality of the facility. The application of a doorknob on one side and for instance, a magnetic card reader makes it possible to have a single-side access control where the door leaves open automatically after the card reader is decoded.

Cutting off voltage from the automation system during a fire alarm causes the self-closing of the door leaves. In such a case, the door can be manually opened.

Hardware applied:

- SLIMDRIVE EMD-F of GEZE company (**Photo 10**)
 - supply 230 V AC 50/60 Hz
 - power 230 W
 - supply to external devices 24 V DC
- 24 V DC averse electric strike
- automatic flush bolts - only for double-leaf doors



Photo 10. SLIMDRIVE EMD-F

HINGES

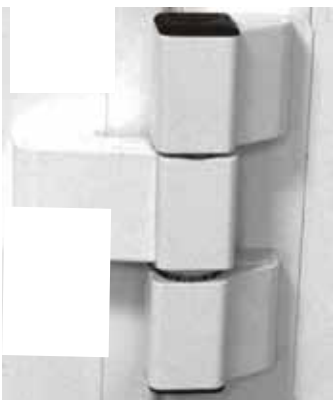

three-part hinge



roller hinge

Photo 11. Three-part and roller hinges

AIR VENT DOORS AND WINDOWS

According to the tests, over 90% of building fire victims die because of smoke or toxic gas poisoning. Air vent doors/windows serve to supply air to the facility, to remove the smoke and toxic gases from the emergency exits and premises. For this purpose, fire-resistant doors are equipped with the so-called pushers which are connected to the SAP system and during an intensive accumulation of smoke, they automatically open the leaves.

The doors/windows with pushers must be equipped in an averse electric strike which opens the moment the pusher's operation starts. After opening the leaf, the voltage is cut off from the electric strike and it remains closed. The application of electric strike is necessary because the door leaf must have a chance to be automatically opened without the necessity to press the handle and to release the lock latch.

Hardware applied:

K600 pusher of GEZE company (**Photo 12**)

- 24V DC supply
- force of pressure 500 N
- rated current 1.2 ÷ 1.25 A-

24V DC averse electric strike

- automatic flush bolts (for double-leaf doors)
- adjustor of closing sequence (for double-leaf doors)
- the pushers shall be mounted exclusively with the help of rivet nuts

VENTILLATION GRILLES

ALUFIRE company offers ventilation grilles for fire resistant doors. They are applied in premises where gravitation ventilation is applied.

Basic parameters of grilles:

- external dimensions 300x 150 mm
- color of front cover, according to the RAL palette
- air flow 295 cm³/s

Each fire-resistant door with an aerating/air vent function and equipped with pushers must be connected to the fire signaling system and at the door, smoke sensors along with temperature sensors shall be mounted. The type of sensors applied, the centre, the distances from the doors and their number shall be in accordance with the design of the fire signalling system. In case of extensive smoke, the door shall be automatically opened to supply fresh air and the smoke shall be removed by gravitation or mechanically through the smoke damper to carry out a quick and efficient evacuation. If the fire causes the temperature to start rising around the opened door, the aerating/air vent door shall close automatically, owing to a signal of a temperature sensor sent from the centre of fire signalling system, to create a permanent barrier for fire. Only the properly designed and mounted outfit shall ensure the proper operation of fire-resistant aerating/air vent door.



Photo 12. Pusher for aerating/air vent door



Photo 13. ALUFIRE door with ventilation grilles

TYPES OF INFILLS AND COLORS APPLIED - MOUNTING

INFILLS OF DOOR-LEAVES AND WALL SEGMENTS

In the first quarter of 2011, we launched a fire resistant glass cutting line.

The investment was related to the dynamic growth in orders of the recent years and its purpose was to shorten the lead times for carrying out orders, and to improve competitiveness. Alufire is the only producer of fire resistant joinery in the Polish market that is able to cut glass in EI30

and EI60 classes. We apply this most frequently to panes of the three largest fire resistant glazing manufacturers in Poland: AGC, Pilkington and Vetrotech.

Non-transparent infills for door leaves and wall segments are made of fire-resistant panels which are clad on both sides with aluminium or steel sheet, powder-coated in any colour.

Figure 19. Examples of non-typical shapes of the resistant construction

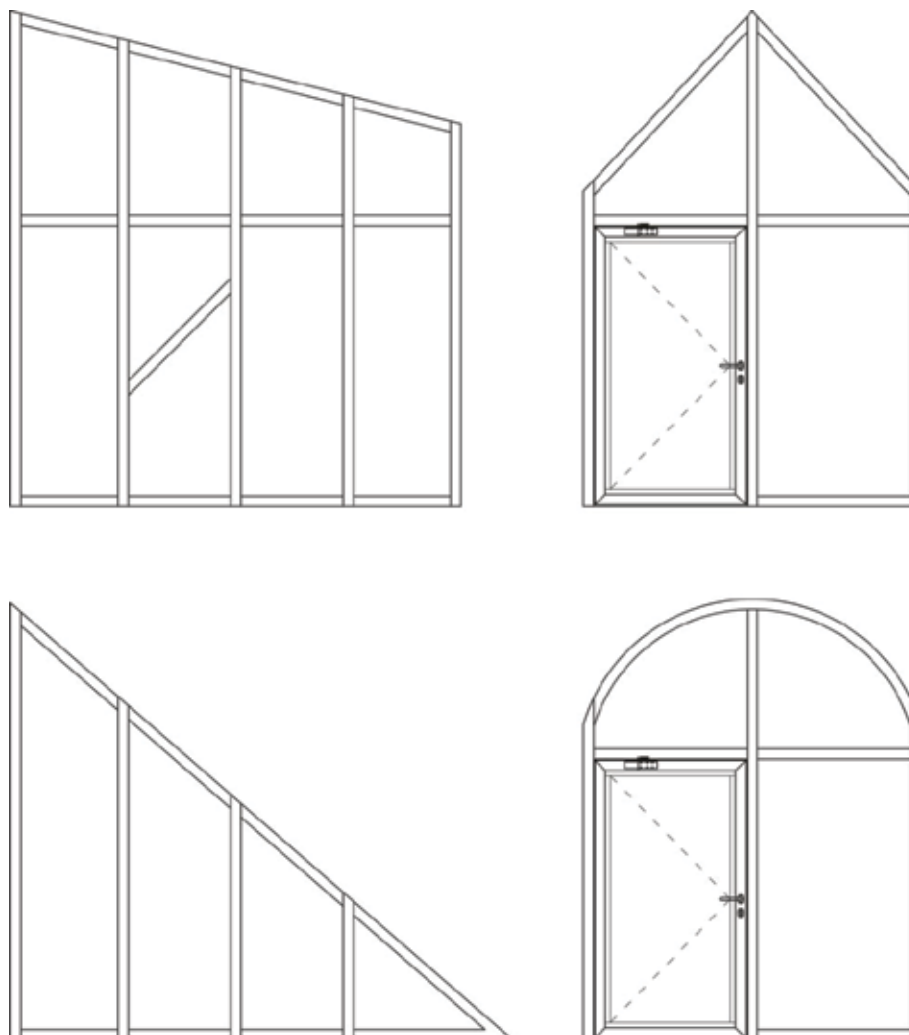

JOINERY COLOR

The surfaces of the profiles and non-transparent infills may be painted in any colour the customer needs, according to the RAL, NCS and DECORAL palettes. We can apply a wood-like veneer and profile anodising. We can manufacture the joinery in two colours. You can select metallic or matte varnish, with a smooth or coarse texture.

The coats are made in the DECORAL system with texture, design and colours which resemble tree annual rings (of pine, apple,

oak, mahogany and many other trees). Varnish coats applied by us are characterised by an extreme resistance to abrasion and are durable in conditions of external exposure.

ALUFIRE may also suggest profiles with a protective coat which prevents aluminium profiles against corrosion. During tests carried out at BRI in Warsaw, our profiles achieved the corrosion category class **C4**, according to EN ISO 12944-2:2001, which signifies high resistance to corrosion.

MOUNTING

To ensure long-term and problem free operation, joinery must be mounted correctly. The door and wall segments can only be mounted by authorised installers. Such licences are granted to authorised mounting teams and, in certain instances, an ALUFIRE Representative may be delegated to supervise, assist and advise during mounting. An important component of the proper mounting of

ALUFIRE fire resistant joinery is the steel angle bars which fix the infill of the construction in the frame. A clearance shall be maintained between the pane and angle bars ranging from 1 to 2 mm (0.5 - 1 mm per each side). This is necessary because of pane swelling during a fire and/or damage (if any) during mounting (**Photo 14**).

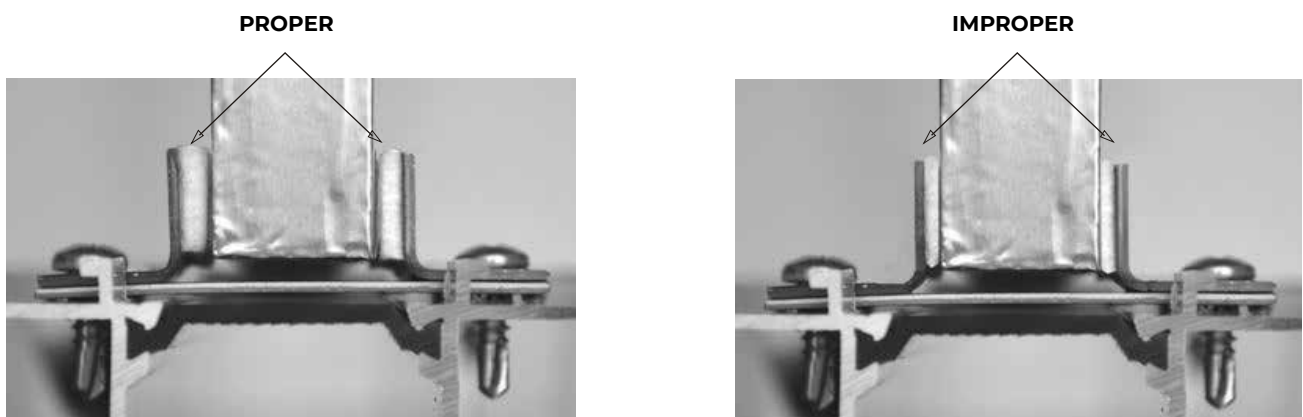

Photo 14. Proper mounting (felt washer, not deformed) and improper mounting (lack of clearance caused by non-parallel screwing of steel angle bar or by use of inappropriate angle bar)

A detailed scope of cross-bar construction mounting is presented in the Mounting Manual, which can be downloaded at: <http://www.alufire.com/en/documents>

LPCB® www.lpcb.co.uk

Certificate of Product Approval
 Certificate Number: 1406a Issue: 01

ALUFIRE Sp.z o.o.Sp.k.
 Ul. Warszawska 64a,
 87-148 Lysymice k. Torunia
 Poland

is authorized to use the LPCB mark in association with the products listed in this certificate and approve having complied with the requirements of the standards as detailed below.

Products Fire Resistant Glazing ALUFIRE E30 ALUFIRE E60 ALUFIRE E120 ALUFIRE VISION LINE E30 ALUFIRE VISION LINE E60	Standards 1158 - Requirements and tests for fire resistant glazing systems
---	--

This Certificate is maintained and held in force through regular surveillance activities and subject to the corresponding ISO 9001 Certificate being maintained.

Damen Ward Damen Ward 13 March 2017 13 March 2017
 Signed for LPCB Certification Scheme Manager Date of Issue Date of Test Issue

ISO 9001 Rev. 0.5

Page 1 of 8

LPCB® www.lpcb.co.uk

Certificate of Product Approval
 Certificate Number: 1406b Issue: 01

ALUFIRE Sp.z o.o.Sp.k.
 Ul. Warszawska 64a,
 87-148 Lysymice k. Torunia
 Poland

is authorized to use the LPCB mark in association with the products listed in this certificate and approve having complied with the requirements of the standards as detailed below.

Products Fire Doorsets ALUFIRE E30 single leaf ALUFIRE E30 double leaf ALUFIRE E60 single leaf ALUFIRE E60 double leaf	Standards LPS1056 - Requirements for the LPCB approval and listing of fire doorsets, lift landing doors and shutters
--	--

This Certificate is maintained and held in force through regular surveillance activities and subject to the corresponding ISO 9001 Certificate being maintained.

Damen Ward Damen Ward 13 March 2017 13 March 2017
 Signed for LPCB Certification Scheme Manager Date of Issue Date of Test Issue

ISO 9001 Rev. 0.5

Page 1 of 11

Institut Techniki Budowlanej
Instytut Techniki Budowlanej

APROBATA TECHNICZNA ITB
AT-15-6520/2016

Przebiegowe drzwi wewnętrzne i zewnętrzne oraz zestawy wyrobów do wykonywania przeciwpożarowych ścian wewnętrznych i zewnętrznych systemu ALUFIRE® z kształtowników aluminiowych z przekładką termiczną

ALUFIRE Sp. z o.o. z ograniczoną odpowiedzialnością Sp. k.
 ul. Warszawska 64 A, 87-148 Lysymice k. Torunia

Przebiegowe drzwi wewnętrzne i zewnętrzne oraz zestawy wyrobów do wykonywania przeciwpożarowych ścian wewnętrznych i zewnętrznych systemu ALUFIRE® z kształtowników aluminiowych z przekładką termiczną

ITB
 Warszawa, 21 Październik 2016 r.

Institut Techniki Budowlanej
Instytut Techniki Budowlanej

ANEKS nr 1
DO APROBATY TECHNICZNEJ ITB
AT-15-6520/2016

Przebiegowe drzwi wewnętrzne i zewnętrzne oraz zestawy wyrobów do wykonywania przeciwpożarowych ścian wewnętrznych i zewnętrznych systemu ALUFIRE® z kształtowników aluminiowych z przekładką termiczną

ALUFIRE Sp. z o.o. z ograniczoną odpowiedzialnością Sp. k.
 ul. Warszawska 64 A, 87-148 Lysymice k. Torunia

Przebiegowe drzwi wewnętrzne i zewnętrzne oraz zestawy wyrobów do wykonywania przeciwpożarowych ścian wewnętrznych i zewnętrznych systemu ALUFIRE® z kształtowników aluminiowych z przekładką termiczną

ITB
 Warszawa, 21 Październik 2016 r.

Certyfikat

Standard: ISO 9001:2008
 Numer certyfikatu: 1010-10000000000000000000

Producent wyrobów: **ALUFIRE®**

ALUFIRE Sp. z o.o. z ograniczoną odpowiedzialnością Sp. k.
 ul. Warszawska 64 A, 87-148 Lysymice k. Torunia

Opis wyrobów: Przebiegowe drzwi wewnętrzne i zewnętrzne oraz zestawy wyrobów do wykonywania przeciwpożarowych ścian wewnętrznych i zewnętrznych systemu ALUFIRE® z kształtowników aluminiowych z przekładką termiczną

Opis wyrobów: Drzwi wewnętrzne i zewnętrzne

ITB
 Warszawa, 21 Październik 2016 r.

Instytut Techniki Budowlanej
Instytut Techniki Budowlanej

KRAJOWY CERTYFIKAT
STALOCY WŁAŚCIWOŚCI UŻYTKOWYCH
Nr 005-11919-001010

Przebiegowe drzwi wewnętrzne i zewnętrzne oraz zestawy wyrobów do wykonywania przeciwpożarowych ścian wewnętrznych i zewnętrznych systemu ALUFIRE® z kształtowników aluminiowych z przekładką termiczną

ALUFIRE Sp. z o.o. z ograniczoną odpowiedzialnością Sp. k.
 ul. Warszawska 64 A, 87-148 Lysymice k. Torunia

Przebiegowe drzwi wewnętrzne i zewnętrzne oraz zestawy wyrobów do wykonywania przeciwpożarowych ścian wewnętrznych i zewnętrznych systemu ALUFIRE® z kształtowników aluminiowych z przekładką termiczną

ITB
 Warszawa, 21 Październik 2016 r.

Instytut Techniki Budowlanej
Instytut Techniki Budowlanej

CERTYFIKAT ZGODNOŚCI
ITB-030010

Zestaw wyrobów do wykonywania przeciwpożarowych ścian wewnętrznych i zewnętrznych systemu ALUFIRE® z kształtowników aluminiowych z przekładką termiczną

ALUFIRE Sp. z o.o. z ograniczoną odpowiedzialnością Sp. k.
 ul. Warszawska 64 A, 87-148 Lysymice k. Torunia

Przebiegowe drzwi wewnętrzne i zewnętrzne oraz zestawy wyrobów do wykonywania przeciwpożarowych ścian wewnętrznych i zewnętrznych systemu ALUFIRE® z kształtowników aluminiowych z przekładką termiczną

ITB
 Warszawa, 21 Październik 2016 r.

Instytut Techniki Budowlanej
Instytut Techniki Budowlanej

REPUBLICKÝ ATESTOVÝ LIST
ATTESTOVANÝ SYSTÉM
ATTESTOVANÝ SYSTÉM

Przebiegowe drzwi wewnętrzne i zewnętrzne oraz zestawy wyrobów do wykonywania przeciwpożarowych ścian wewnętrznych i zewnętrznych systemu ALUFIRE® z kształtowników aluminiowych z przekładką termiczną

ALUFIRE Sp. z o.o. z ograniczoną odpowiedzialnością Sp. k.
 ul. Warszawska 64 A, 87-148 Lysymice k. Torunia

Przebiegowe drzwi wewnętrzne i zewnętrzne oraz zestawy wyrobów do wykonywania przeciwpożarowych ścian wewnętrznych i zewnętrznych systemu ALUFIRE® z kształtowników aluminiowych z przekładką termiczną

ITB
 Warszawa, 21 Październik 2016 r.

ZUS
Technický a zkušební ústav státního práva, s.p.

CERTIFIKÁT VÝROBKU
Č. 20620201-0000-000007

Przebiegowe drzwi wewnętrzne i zewnętrzne oraz zestawy wyrobów do wykonywania przeciwpożarowych ścian wewnętrznych i zewnętrznych systemu ALUFIRE® z kształtowników aluminiowych z przekładką termiczną

ALUFIRE Sp. z o.o. Sp. s.
 ul. Warszawska 64 A, 87-148 Lysymice k. Torunia

Przebiegowe drzwi wewnętrzne i zewnętrzne oraz zestawy wyrobów do wykonywania przeciwpożarowych ścian wewnętrznych i zewnętrznych systemu ALUFIRE® z kształtowników aluminiowych z przekładką termiczną

ZUS
 Praha 1, 20.10.2016

Instytut Techniki Budowlanej
Instytut Techniki Budowlanej

SWIADCENSTWO BADAWIENIOWE
OPORNOŚCI NA WŁAMANIE

Przebiegowe drzwi wewnętrzne i zewnętrzne oraz zestawy wyrobów do wykonywania przeciwpożarowych ścian wewnętrznych i zewnętrznych systemu ALUFIRE® z kształtowników aluminiowych z przekładką termiczną

ALUFIRE Sp. z o.o. z ograniczoną odpowiedzialnością Sp. k.
 ul. Warszawska 64 A, 87-148 Lysymice k. Torunia

Przebiegowe drzwi wewnętrzne i zewnętrzne oraz zestawy wyrobów do wykonywania przeciwpożarowych ścian wewnętrznych i zewnętrznych systemu ALUFIRE® z kształtowników aluminiowych z przekładką termiczną

ITB
 Warszawa, 21 Październik 2016 r.

QUOTATION INQUIRY

Quotation inquiries can be sent directly to:
info@prospectfire.co.uk

Filing a quotation inquiry, the following should be stated:

- dimensions of required doors/screens/windows and/or structural opening dimensions
- specification of fire resistance class (EI15/EI30/EI45/EI60/EI120) and whether door smoke resistance is required
- whether constructions are to be internal or external (with raised thermal insulated power)
- additional requirements related to hardware (for instance anti-panic lever, electric strike, electric retainer)
- colour, according to corresponding palette
- sound reduction
- direction of opening (**Figure 20**)

Figure 20. Setting out the direction of door opening

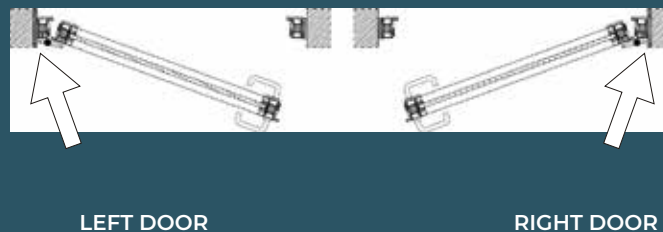

Direction of door opening is set out, standing on the side of the hinges

ALUFIRE®

Distributor and installer in the
UK:



PROSPECT FIRE

YOUR PARTNER IN FIRE SAFETY

Prospect Fire Ltd.

Unit 1 Woodgate's Farm,
Woodgate's End, Dunmow,
Essex CM6 2BN

UK

T. +44 01279 354988

E. info@prospectfire.co.uk

W. www.prospectfire.co.uk